



ERB2



Mounting instruction for Electronic Rotating Beacon (ERB2) Electronic Rotating Beacon for ultra-light aircraft

Dear customer,
the Electronic Rotating Beacon 2 (ERB2) is a highly innovative product which contributes to save airspace.

The new LED technology allows an incredibly excellent, red light with only approx. 10% of the input power compared with conventional lights. The casting in a high-optical plastic makes the ERB absolutely insensitive against water, vibrations and other environmental influence. The efficiency of the output is much higher, than with conventional electric light bulbs. The self-warming of the ERB is low and can be determined as safe. To avoid overheating, the heat balance is controlled electronically.

The ERB2 has additionally a serial FLARM-Interface. With this interface (19.200 Baud, 8 Bit, No Parity, 1 Stop-Bit) a Power-FLARM unit can send the emergency level (0-3) and thus control the action replay of the ERB. **Important:** connect the shielding of the cable only at the ground of the Power-FLARM to avoid buzz loops and therefore interferences.

The ERB2 is part of our energy strategy „Intelligent Synchronisation“. This increases the visibility of aircrafts and improves the energy management at once. Available elements of the Intelligent Synchronisation are: EPL2, EPTA-LSA, ELL50, ELL60, ELL80is, ERBis, ERB-His, ERB-SFi, ERB2, ACL4.

This rotating beacon for ultra-light aircraft is designed to be mounted at a suitable position at the tail unit or at the top of the stabilizer. Please adhere to the following instructions for a professional mounting of the ERB.

The illumination angle complies to the regulations for general aviation.

Required materials and tools

- 3-core twisted cord, according to the length of fuselage (5 - 8 meters)
- 2 screws, approx. Ø 4 mm x 30 - 35-mm length
- soldering iron, tin solder
- shrink hose (enclosed)

Recommendations

Cable

We recommend a double core, flexible and twisted cable with a cross section of at least 1.5 mm² and minimum 0,5 mm² for synchronisation cable. In case of doubt, you can order the suitable cable from Thiesen Electronics GmbH. Use a single-wire shielded cable for the FLARM-Interface.

Adhesion

We recommend standard silicon in a tube. It is available in do-it-yourself markets. This adhesion is strong and in case of a dismantling you only need a sharp knife. We strongly advise against using other kinds of adhesion, like polyester or epoxy resin.

Mounting

Use 2 metal screws (Ø 4 mm x 30 - 35 mm) to fix the ERB and a thin layer of silicon to paste it to the required position. By the use of silicon twisting of the ERB is prevented and sealing against dirt and water is guaranteed. **Use only screws that do not corrode!** The ERB must be mounted parallel to the longitudinal axis and vertically to the yaw axis of the aircraft (see illustration 1).

Illustration 1

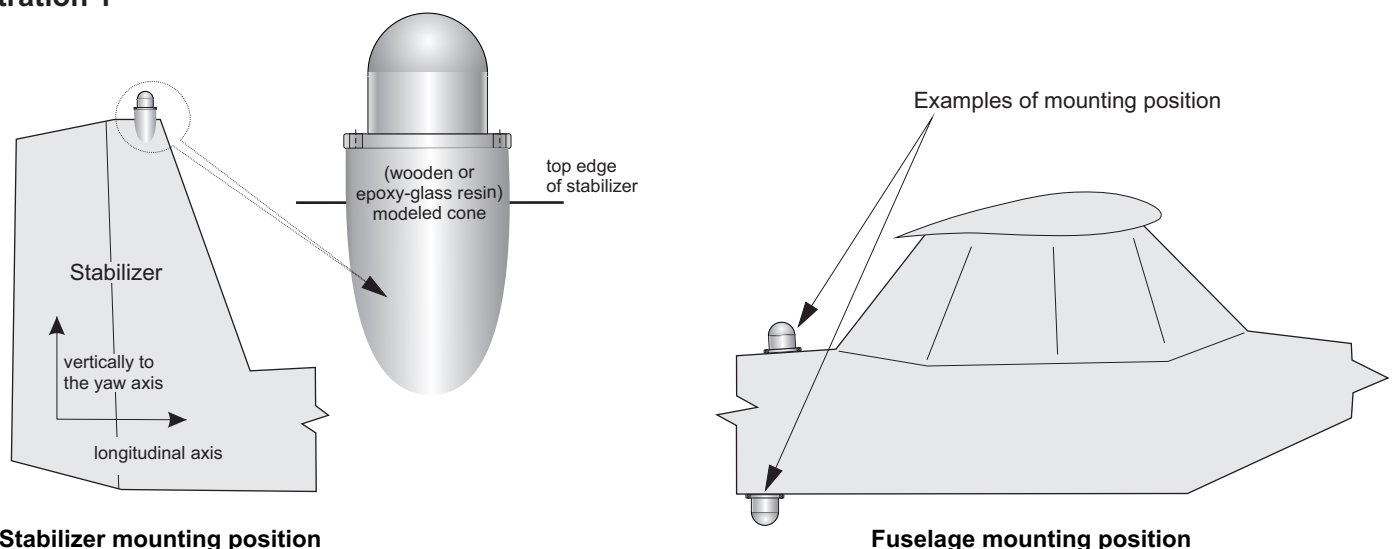

Pasting

Apply only as much silicone as required to paste the ERB plane (see illustration 2).

After fixing the ERB to the required position, slightly tighten the screw. With your moistened finger using dish liquid clean off any laterally dispensable silicon, a smooth transition can be modeled between the fuselage and the ERB.

Silicone needs time to cure (vaporization of acetic acid). The best results are achieved at a temperature of 20 deg. Celsius (68 deg. Fahrenheit). Just follow the handling instructions of the silicone. The final firmness (stability) will be reached after a few days.

Illustration 2

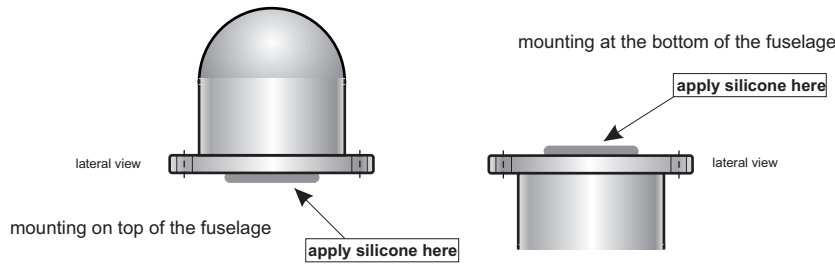

Electric power supply / cable connection to the aircraft system (12 Volts)

The best connection is solder with additional shrinking of the soldering joint with a shrink hose (enclosed). Only use solder for electronic soldering never use cored solder. It contains acids which cause corrosion!

Synchronisation

The ERB2 has an additional yellow synchronisation cable to synchronize with EPL2 or EPTA. Just connect the yellow cables (also with ELL50 where required). The intelligent synchronisation scales the light pulse (and thereby the current pulse). This will prevent the battery respectively the generator by constant current consumption. If you do not use the synchronisation, connect the yellow cable with +12V (red cable).

Important notes

Carefully mount the cables inside the rudder and/or the fuselage. Connect the cables professionally to the aircraft system (**red = positive, black = negative, yellow = synchronisation, green = FLARM**) and to a 5 Amps fuse protection. Luster terminals are not suitable to connect cables. There is a good selection of suitable crimp connections in various shops.

The ERB is provided with overload protection. In case of over voltage the protector switches off the ERB. After reset or voltage drop the ERB is again fully functional. The automatic overload protector shall be activated at a voltage above 18 Volts. (If the voltage reduces to a value below 18 Volts, the ERB will again be functioning)

Servicing / maintenance

For additional UV protection, use varnish. Should the ERB be scratched, use a good polish to refurbish the damages. With slightly deeper scratches use wet sandpaper with very fine granulation (800-1000) carefully polish again. Do not use aggressive chemicals like gasoline or solvent.

For day to day cleaning use soap water!

Some insect removers and detergents forces embrittlement of epoxy based plastics and laminates. Use only aircraft certified products. **If the aircraft can not hangarized, please cover the lamps to prevent surface aging!**

Technical data

Operating voltage: 10-17 volts (DC), typically 12.8 - 13.4 volts
Input : approx. 16 watts
Fuse : 5 ampere (fusible cut-out or automatic fuse)
Dimensions : 61 x 44 x 56 mms
Drill hole : 4.5 mm
Weight : approx. 105 grams with connecting cables
Warranty : 5,000 operating hours or max. 3 years

Wiring diagram:

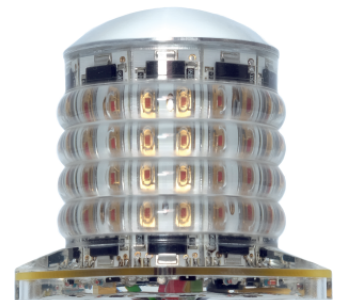
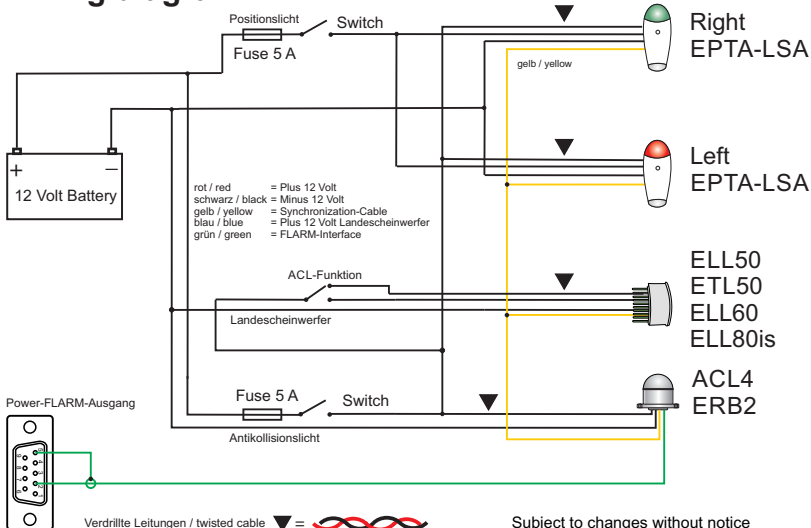

**5.000 hours or max. 3 years
assured luminous duration
Made in Germany**

Im Tiegel 9
36367 Wartenberg
Germany
Tel.: +49 (0) 66 41 - 979 - 0
eMail: info@thiesen.com
www.thiesen.com
www.flugzeuglichter.de

