



Mounting instruction for electronic landing light (ELL60)

Dear customer,

the electronic landing light (ELL) is a highly innovative product which contributes to save airspace. A special feature of the LED based Landing light is the integrated Anti Collision Light (ACL). Thus the ELL60 is a landing light and an ACL in forward direction of the flight. This increases the visiblensness of the a/c in flight considerably.

The newly developed "Intelligent Synchronization" schedules the Light pulsations so that there are no overlap of the individual lighting functions. This scheduling of pulsations Reduces required battery and generator current requirements as if only one light was on at any given moment (see illustration 1).

Now the new LED technology allows an incredibly excellent, white light with only approx. 10% of the input power compared with conventional lights. The casting in a high-optical plastic makes the ELL60 absolutely insensitive against water, vibrations and other environmental influence. The efficiency of the output is much higher, than with conventional electric light bulbs. The self-warming of the ELL60 is low and can be determined as safe. To avoid overheating, the heat balance is controlled electronically.

This electronic landing light for aircraft (NON-TSO'd) is designed to be mounted at a suitable position at the nose unit or inside the wing. Please adhere to the following instructions for a professional mounting of the ELL60.

The illumination angle complies to the regulations for general aviation.

Important: Due to high wattage (60 Watts), it is mandatory to put a cooling system in place (see illustration 2, 3). Warranty is voided if mandatory cooling system is not in place!

Required materials and tools

- 4 x 1-core cord, according to the length of fuselage (5 - 8 meters),
- clear silicone,
- soldering iron, tin solder,
- shrink hose (is enclosed).

Recommendations

Cable

We recommend a single core, flexible cable with a cross section of at least 1.5 mm² and one cable with a cross section of 0,75mm² (yellow=Syncronisation). The ELL is already wired with flexible wire for simple connection with the landing light and the ACL.

Adhesion

We recommend standard silicon in a tube. It is available in do-it-yourself markets. This adhesion is strong and in case of a dismantling you only need a sharp knife. We strongly advise against using other kinds of adhesion, like polyester or epoxy resin.

Mounting

For the first time we have designed a new cooling system for the ELL60. At our newly developed central cooling the cooling air is passed through the central of the landing lights directly to the heatsink. Only with this new system it is possible to implement this high performance on such a small space.

For new installations we suggest to use our new mounting tubus with integrated cooling air channel. This mounting tubus is laminated with epoxy resin according on demand. We deliver two variable mounting tubes with different air passage, one with cooling air admittance on the front side or the other through separate entrance (see picture).

The version with front entrance admittance is intended for cowling mounting or wheel pants mounting. The mounting tubus with edgewise entrance is intended for plane mounting, but can also be used for cowling mounting if it is possible to aspirate the cooling air at the motor cooling air admittance. The landing light can be fixed with some small drops of silicon on the four mounting rails at the inside of the mounting tubus.

Cooling of the landing light is strongly necessary to ensure a correct function.

Illustration 2: Mounting at nose unit

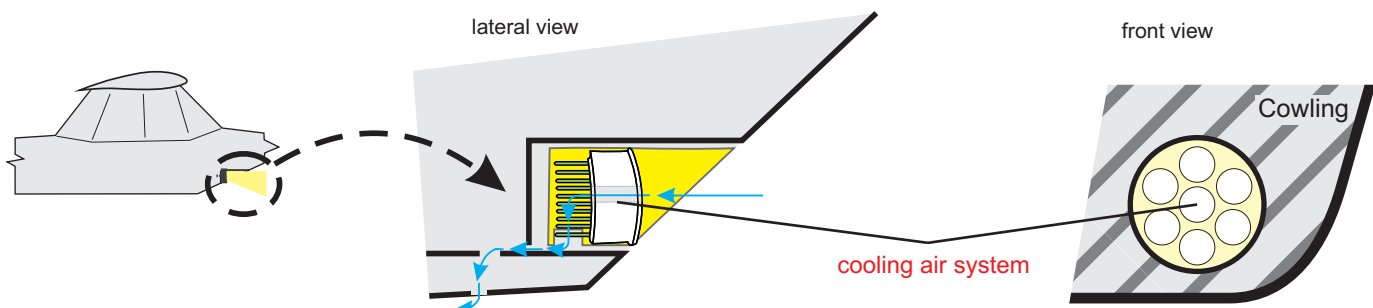
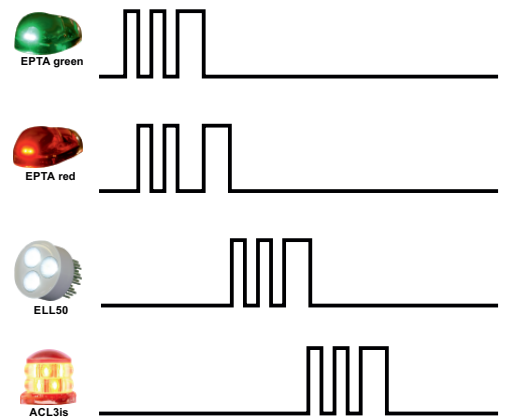

Illustration 1



Intelligent Synchronisation = Intelligent Powermanagement

Pasting

Apply only as much silicone as required to paste the ELL plane. With your moistened finger, using dish liquid, clean off any laterally dispensable silicone, a smooth transition can be modeled between the wing and the ELL.

Please make sure that mandatory cooling is not obstructed by excess silicon.

Silicone needs time to cure (vaporization of acetic acid). The best results are achieved at a temperature of 20° Celsius (68° Fahrenheit). Just follow the handling instructions of the silicone. The final firmness (stability) will be reached after a few days.

Illustration 3: Mounting at nose unit with alternative cooling air system

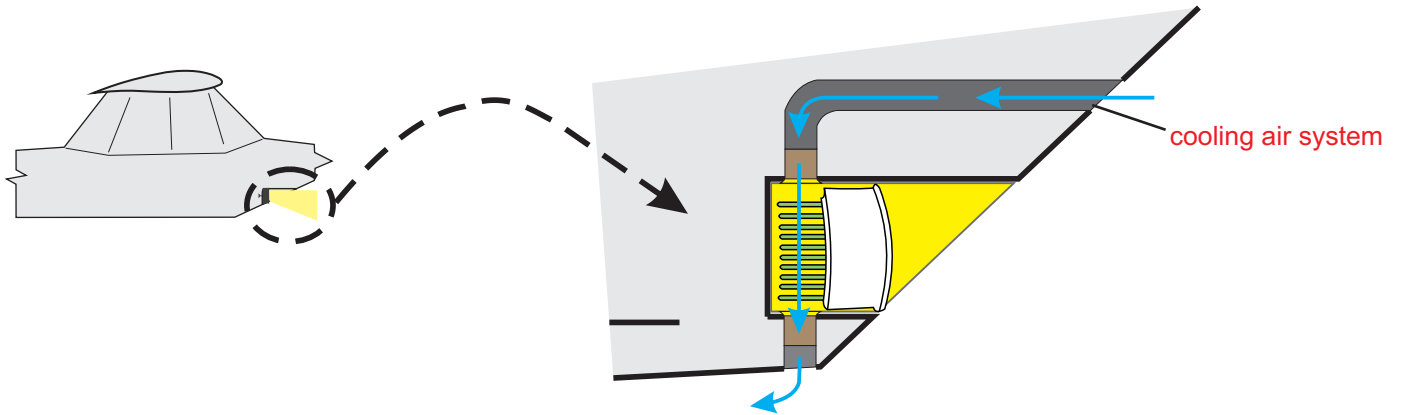

Electric power supply / cable connection to the aircraft system (12 Volts)

The best connection is solder with additional shrinking of the soldering joint with a shrink hose (enclosed). Only use solder for electronic soldering - never use cored solder. It contains acids which cause corrosion!

Important notes

Carefully mount the cables inside the wing and/or the fuselage. Connect the cables professionally to the aircraft system (**RED = positive ACL**, **BLACK = negative**, **blue = positive Landing Light**, **yellow = Synchronisation**) and to a 5 Amps fuse protection. Luster terminals are not suitable to connect cables. There is a good selection of suitable crimp connections in various shops. If synchronisation is not in use, please connect the yellow cable to +12V (red cable).

The ELL60 is provided with overload protection. In case of over voltage the protector switches off the ELL60. After reset or voltage drop the ELL60 is again fully functional. The automatic overload protector shall be activated at a voltage above 18 Volts (if the voltage reduces to a value below 18 Volts, the ELL will again be functioning).

Servicing / maintenance

Should the ELL60 be scratched, use a good polish to refurbish the damages. With slightly deeper scratches use wet sandpaper with very fine granulation (800-1000) carefully polish again. Do not use aggressive chemicals like gasoline or solvent.

For day to day cleaning use soap water!

Some insect removers and detergents forces embrittlement of epoxy based plastics and laminates. Use only aircraft certified products.

If the aircraft can not hangarized, please cover the lamps to prevent surface aging!

Technical data

Operating voltage : 10-17 volts (DC), typically 12.8 - 13.4 volts
 Input : approx. 60 watts
 Fuse : 5 ampere (fusible cut-out or automatic fuse)
 Diameter : approx. 60 mm
 installation depth : approx. 50 mm
 Weight : approx. 130 grams with connecting cables
 Warranty : 5,000 operating hours or max. 3 years



5.000 hours or max. 3 years assured luminous duration

Made in Germany

Illustration 4: wiring diagram

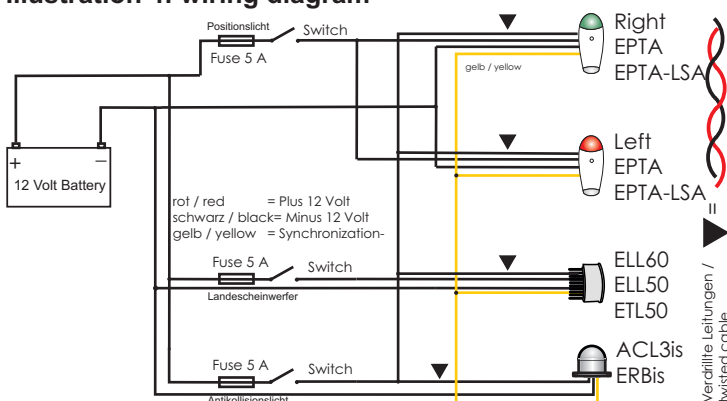

Subject to changes without notice

Im Tiegel 9
 36367 Wartenberg
 Germany

Phone: +49 (0) 66 41 - 979 - 0

eMail: info@thiesen.com

www.thiesen.com

www.flugzeuglichter.de



THIESEN
 HARDWARE
 SOFTWARE
 DESIGN
 G M B H